

Technical Regulations**SuperBike 1000 Technical Specifications**

The following rules are intended to permit limited changes to the homologated motorcycle in the interests of safety and improved competition between various motorcycle concepts.

EVERYTHING THAT IS NOT AUTHORISED AND PRESCRIBED IN THIS RULE IS STRICTLY FORBIDDEN

If a change to a part or system is not specifically allowed in any of the following articles, then it is forbidden

Superbike motorcycles require an FIM homologation. All motorcycles must comply in every respect with all the requirements for Road Racing as specified in these Regulations, unless they are already equipped as such on the homologated model.

The appearance from both front, rear and the profile of Superbike motorcycles must (except when otherwise stated) conform to the homologated shape (as originally produced by the manufacturer). The appearance of the exhaust system is excluded from this rule.

1. Motorcycle specifications

- 1.1. All parts and systems not specifically mentioned in the following articles must remain as originally produced by the manufacturer for the homologated motorcycle

2. Displacement capacities

- 2.1. The following engine configurations comprise the Superbike class:

- 2.1.1. Over 750 cc up to 1103 cc 4-stroke 3 and 4 cylinders
2.1.2. Over 850 cc up to 1200 cc 4-stroke 2 cylinders

- 2.2. The displacement capacity, bore and stroke (new), must remain at the homologated size. All machines must be normally aspirated.

3. Balancing various motorcycle concepts

- 3.1. In order to equalise the performance of motorcycles with different engine configurations, changes in the minimum weight may be applied according to their respective racing performances. The decision about applying a handicap system to a respective class is taken by the FMSCT/TSB Commission at any time.

4. Minimum Weights

- 4.1. The minimum weight starting the season will be:

1000 cc.	3 & 4 Cylinders	174 Kg.
1103 cc.	4 Cylinders	189 Kg.
1200 cc.	2 Cylinders	174 Kg.

Technical Regulations

- 4.2. At any time of the event, the weight of the whole machine (including the tank and its contents) must not be lower than the minimum weight.
- 4.3. There is no tolerance on this minimum weight.
- 4.4. During the final technical inspection at the end of the race, the selected motorcycles will be weighed in the condition they finished the race, and the established weight limit must be met in this condition. Nothing may be added to the motorcycle. This includes all fluids.
- 4.5. During the practice and qualifying sessions, riders may be asked to submit their motorcycle to a weight control. In all cases the rider must comply with this request.
- 4.6. The use of ballast is allowed to stay over the minimum weight limit and may be required due to the handicap system. The use of ballast and weight handicap must be declared to the FMSCT/TSB Technical Director at the preliminary checks.
- 4.7. Fuel and fuel tank can be used as ballast. Nevertheless, the verified weight may never fall below the required minimum weight.
- 4.8. In case of accident, fairing or damaged parts could be taking and weight with bike for final weight measurement.

5. Number Plate Colours

- 5.1. The background colours and figures (numbers) for SuperStock are **white background with black numbers**:

- 5.2. The sizes for all the front numbers are:

Minimum height:	140 mm
Minimum width:	80 mm
Minimum stroke:	20 mm
Minimum space between numbers	10 mm

- 5.3. The size for all the side numbers is:

Minimum height:	120 mm
Minimum width:	70 mm
Minimum stroke:	25 mm
Minimum space between numbers	10 mm

- 5.4. The allocated number (& plate) for the rider must be affixed on the machine as follows:

- 5.4.1. once on the front, either in the centre of the fairing or slightly off to one side. The number must be centred on the white background with no advertising within 25mm in all directions.
- 5.4.2. once on each side of the motorcycle. Alternatively, once across the top of the rear seat section with the top of the number towards the rider. The rear

Technical Regulations

and side numbers are optional. The preferred location for the numbers on each side of the motorcycle is on the lower rear portion of the main fairing near the bottom. The number must be centred on the white background.

- 5.4.3. The numbers must use sufficiently legible fonts.
 - 5.4.4. The background colour must be clearly visible around all edges of the number (including outline). Reflective or mirror type numbers are not permitted.
 - 5.4.5. Numbers cannot overlap.
- 5.5. In case of a dispute concerning the legibility of numbers, the decision of the FMSCT/TSB Technical Director will be final.

6. Fuel

- 6.1. The fuel is controlled, only Benzene 95 Octane, **Gasohol 95 (E10)** or E20 can be used. Fuel must be obtained at the circuit(s) or supplied by the Promoter(s). No additive is permitted. No premium gasoline 95 octane is allowed

7. Tyres

- 7.1. Only Racing slick tyres are permitted.
- 7.2. Only FMSCT/TSB homologated tyres in FMSCT All Thailand Championship are permitted.
- 7.3. The maximum number of front and rear slick tyres allowed to use during the qualifying practices and race are TWO (2) Front and TWO (2) Rear. Both front and rear slick tyres need to be marked with a tyre sticker. **In case of two race consecutively (Final Round) TWO (2) Front and THREE (3) Rear are allowed.**
- 7.4. The wet tyres will not need to be marked with a tyre sticker and will not be considered in the total number of tyres available for use.
- 7.5. During the preliminary technical inspection, the teams will be delivered the adhesive stickers used for marking the tyres. Each team will be responsible of marking their tyres.
- 7.6. The FMSCT/TSB Technical Director may perform random controls during the qualifying practices. If the riders are shown a red flag during the practice or the race/s, the Permanent Race Direction is allowed to authorise the use of a supplementary tyre. All checked tyres must be easily identifiable with a colour marking or a numerical system.
- 7.7. The use of tyre warmers is allowed.
- 7.8. Any modification (cutting, grooving) is forbidden.
- 7.9. In case of a technical problem, the FMSCT/TSB Technical Director will take a decision about the problem.

Technical Regulations

8. Engine

A maximum of 2 engines is permitted for each race weekend. Engines must be sealed before the start of the first practice of race weekend during the scrutineering and safety checks

Any engine change must be accompanied by a written request stating the reason for change, all engine seals must not be removed without permission from the FIM Asia Technical Director/steward, and head of scrutineering team. The FIM Asia Technical Director/steward and head of scrutineering team may request to examine the retired engine. Engine must be sealed with valve cover and bike-frame, seal wire must be tightened properly. Picture can be referred according to appendix 1.

Apart from the above requirement, engines will be requested to be sealed at any time during the event by the FIM Asia Technical Director/steward and head of scrutineering team when the need arises.

8.1. Fuel Injection System

- 8.1.1. The original homologated fuel injection system must be used.
- 8.1.2. b. The fuel injectors can be changed or upgraded from the original specification and manufacture.
- 8.1.3. c. Bell mouths must remain as originally produced by the manufacturer for the homologated motorcycle.
- 8.1.4. d. Butterfly valves can not be changed or modified.
- 8.1.5. e. Variable intake tract devices cannot be added if they are not present on the homologated motorcycle and they must remain identical and operate in the same way as the homologated system. All the parts of the variable intake tract device must remain exactly as homologated.
- 8.1.6. f. Air and air/fuel mixture can go to the combustion chamber exclusively through the throttle body butterflies.
- 8.1.7. g. Electronically controlled throttle valves, known as 'ride-by-wire', may be only used if the homologated model is equipped with the same system. Software may be modified but all the safety systems and procedures designed by the original manufacturer must be maintained.
- 8.1.8. Throttle body clamp may be changed.

8.2. Cylinder Head

- 8.2.1. Cylinder head must be the originally fitted and homologated part with no modifications allowed Except to service valve guides.
- 8.2.2. Cylinder head must be the originally fitted and homologated part with no modifications allowed.
- 8.2.3. No material may be added or removed from the cylinder head.
- 8.2.4. No additional welding is permitted.

Technical Regulations

- 8.2.5. The head gasket is free.
- 8.2.6. The valves, valve seats, guides, springs and retainers must be the originally fitted and homologated part with no modifications allowed.
- 8.2.7. Valve guide can be change for service maintenance purpose. But material must be same as homologated part. And in the original position as supplied by the manufacturer of the homologated motorcycle.
- 8.2.8. Valve lapping as in normal service maintenance is permitted.

8.3. Camshaft

- 8.3.1. The method of drive must remain as homologated.
- 8.3.2. The duration and lift are free.
- 8.3.3. The cam chain or cam belt tensioning devices(s) are free.

8.4. Cam sprockets or Gears

- 8.4.1. Cam sprockets or cam gears may be altered or replaced to allow the degreeing of the camshafts.

8.5. Cylinders

- 8.5.1. No modifications are allowed.

8.6. Pistons

- 8.6.1. No modifications are allowed (including polishing and lightening).

8.7. Piston rings

- 8.7.1. No modifications are allowed. (All piston rings must be fitted.)

8.8. Piston pins and Clips

- 8.8.1. No modifications are allowed.

8.9. Connecting rods

- 8.9.1. No modifications are allowed (including polishing and lightening).

8.10. Crankshaft

- 8.10.1. No modifications are allowed (including polishing and lightening). *Only balancing is allowed.

8.11. Crankcase and all other Engine Cases

- 8.11.1. Crankcases must remain as homologated. No modifications are allowed (including painting, polishing and lightening).

Technical Regulations

- 8.11.2. It is not allowed to add a pump used to create a vacuum in the crankcase. If a vacuum pump is installed on the homologated motorcycle, then it may be used only as homologated.
- 8.11.3. The secondary cover must cover a minimum of 1/3 of the original cover. It must have no sharp edges to damage the track surface.
- 8.11.4. Plates or crash bars made from aluminium or steel also are permitted in addition to these covers. All of these devices must be designed to be resistant against sudden shocks, abrasions and crash damage.
- 8.11.5. FIM approved covers will be permitted without regard of the material or its dimensions.
- 8.11.6. These covers must be fixed properly and securely with a minimum of three (3) case cover screws that also mount the original covers/engine cases to the crankcases.
- 8.11.7. Oil containing engine covers must be secured with steel bolts.
- 8.11.8. The FMSCT/TSB Technical Director has the right to refuse any cover not satisfying this safety purpose.

8.11.8.1. Lateral covers and protection

- 8.11.8.1.1. Lateral (side) covers may be altered, modified or replaced. If altered or modified the cover must have at least the same resistance to impact as the original one. If replaced, the cover must be made in material of same or higher specific weight and the total weight of the cover must not be less than the original one.
- 8.11.8.1.2. All lateral covers/engine cases containing oil and which could be in contact with the ground during a crash, must be protected by a second cover made from metal such as aluminium alloy, stainless steel, steel or titanium.
- 8.11.8.1.3. Plates or crash bars from aluminium or steel also are permitted in addition to these covers. All of these devices must be designed to be resistant against sudden shocks, abrasions and crash damage.
- 8.11.8.1.4. FMSCT/TSB approved covers will be permitted without regard of the material.
- 8.11.8.1.5. These covers must be fixed properly and securely with case cover screws that also mount the original covers/engine cases to the crankcases.
- 8.11.8.1.6. The FMSCT/TSB Technical Director has the right to refuse any cover not satisfying this safety purpose.
- 8.11.8.1.7. No damaged cases will be permitted unless approved by the FMSCT/TSB Technical Director

Technical Regulations**8.12. Transmission/Gearbox**

- 8.12.1. No modifications are allowed.
- 8.12.2. Quick-shift systems are allowed (including wire and potentiometer) Additions to auto selector mechanism to the gearbox is not permitted. Electronic or hydraulic actuated shifters are not permitted.
- 8.12.3. Countershaft sprocket, rear wheel sprocket, chain pitch and size may be changed.
- 8.12.4. The sprocket cover maybe modified or eliminated.
- 8.12.5. Chain guard as long as it is not incorporated in the rear fender may be removed.
- 8.12.6. Bolts and Nuts on Rear wheel sprocket must not be removed or altered from factory.

8.13. Clutch

- 8.13.1. Aftermarket or modified clutches are permitted. Back torque limiting capacity (slipper) is permitted.
- 8.13.2. Clutch type (wet or dry) and the way of operation (by cable or hydraulic) must remain as homologated.
- 8.13.3. Clutch springs, plate, cable may be changed. Clutch springs are free and pre-load can be changed by adding shims.

8.14. Oil pumps and Oil lines

- 8.14.1. Original equipment oil pumps are required but may be modified: Modifications may include
 - 8.14.1.1. Blueprinting.
 - 8.14.1.2. Changing the pressure relief spring.
 - 8.14.1.3. Reducing gear and housing thickness.
- 8.14.2. The external appearance must remain as homologated.
- 8.14.3. Aftermarket oil sumps and the associated pump pick up will be allowed.
- 8.14.4. Oil lines may be replaced with high pressure braided stainless or equivalent for durability purposes.
- 8.14.5. The internal parts of the water pump may be changed or modified. The drive ratio may be changed. The external appearance must remain as homologated. Water pipes may be modified or replaced

Technical Regulations**8.15. Radiator, cooling system and oil coolers**

- 8.15.1. The original radiator or oil cooler may be altered or replaced from those fitted to the homologated motorcycle.
- 8.15.2. Additional radiators may be added.
- 8.15.3. Oil coolers can be added to those machines not fitted with one as standard. An adaptor may be fitted between the oil filter and the engine to provide supply and return to an oil cooler. The standard heat exchanger may be removed.
- 8.15.4. Radiator fan and wiring may be changed, modified or removed.
- 8.15.5. Oil cooler must not be mounted on or above the rear mudguard.
- 8.15.6. The appearance from the front, rear and profile of the machine must in principle conform to the homologated shape after the addition of additional radiators or oil coolers.
- 8.15.7. Only water is permitted to be used inside the radiator and the entire cooling system. No additives, Antifreeze, "Radiator Coolant" or any other liquid is permitted.

8.16. Air box

- 8.16.1. The air box must remain as originally produced by the manufacturer on the homologated motorcycle but the air box drains must be sealed.
- 8.16.2. The air filters, internal flap type valve, and vacuum fittings may be removed, modified, or replaced with aftermarket parts.
- 8.16.3. Any holes in the airbox to the outside atmosphere resulting from the removal of components must be completely sealed from incoming air.
- 8.16.4. Ram air tubes or ducts may be modified, replaced with aftermarket parts or removed. If tubes/ducts are utilized, they must be attached to the original airbox inlets, modified as above.
- 8.16.5. Velocity stacks may be modified, replaced with aftermarket parts or removed. The only modification permitted to the airbox to allow use of alternate velocity stacks is the removal of internal debris deflectors/plates.

8.17. Fuel supply

- 8.17.1. Fuel pump and fuel pressure regulator can be altered.
- 8.17.2. The fuel pressure can be altered.
- 8.17.3. Fuel lines from the fuel tank to the delivery pipe assembly (excluded) may be replaced.

Technical Regulations

- 8.17.4. The fuel line(s) going from the fuel tank to the carburetion instruments must be located in such a way that they are protected from possible crash damage.
- 8.17.5. Fuel vent lines may be replaced.
- 8.17.6. Fuel filters may be added.
- 8.17.7. Fuel petcock may be altered or replaced from those fitted to the homologated motorcycle.

8.18. Exhaust system

- 8.18.1. Exhaust pipes and silencers may be modified or changed. Catalytic converters must be removed.
- 8.18.2. The number of the final exhaust silencer(s) must remain as homologated. The silencer(s) must be on the same side(s) of the homologated model.
- 8.18.3. For safety reasons, the exposed edges of the exhausts pipe(s)outlet must be rounded to avoid any sharp edges.
- 8.18.4. Wrapping of exhaust systems is not allowed except in the area of the rider's foot or an area in contact with the fairing for protection from heat.
- 8.18.5. The noise limit for Superbike be 107 dB/A (with a 3 dB/A tolerance after the race only)

8.19. Sound level control**8.19.1. Sound limits in force:**

- 8.19.1.1. Noise will be controlled at: Max. 107 dB/A measured at a mean piston speed of 11 m/sec.

8.19.2. Noise control

- 8.19.2.1. Due to the similarity of the piston stroke in different engine configurations within the capacity classes, the noise test will be conducted at a fixed RPM. For reference only, the mean piston speed at which the noise test is conducted is calculated at 11 m/sec.

	2 Cylinders	3 Cylinders	4 Cylinders
Over 750 cc.	5,000 RPM	5,000 RPM	5,000 RPM

8.19.3. Noise control after the competition

In a competition which requires a final examination of machines before the results are announced, this examination can include a noise control measurement of at least the first three machines listed in the final classification. At this final test, there will be a 3 dB/A tolerance.

Technical Regulations**9. Electrics and Electronics****9.1. Ignition / Engine Control System (ECU)**

- 9.1.1. ECU is free and may be replaced.
- 9.1.2. The following Electronic Riding Aids are permitted:
 - 9.1.2.1. 2-way Quickshifter, including Downshift Blipper.
 - 9.1.2.2. Traction Control and Launch Control.
 - 9.1.2.3. These Electronic Riding Aids and its related Hardware may be added if the Machine(s) does not have them as standard.
- 9.1.3. Pit Lane speed limiter is permitted.
- 9.1.4. ECU map selection switch can be added.
- 9.1.5. ECU may relocated.
- 9.1.6. Resistors/load may be added to replace the parts of the electrical system that have been removed (including lights and lambda sensors) to prevent ECU errors.
- 9.1.7. Ignition coils are free
- 9.1.8. Spark plugs may be replaced.
- 9.1.9. Corner by corner or distance/position based adjustments are not allowed.
- 9.1.10. The original speedometer and tachometer may be altered or replaced.
- 9.1.11. Battery is free and can be relocated

9.2. Wiring Harness:

- 9.2.1. The wiring harness and connectors are free
- 9.2.2. The key/ignition lock may be relocated, replaced or removed.

9.3. Generator, alternator, electric starter

- 9.3.1. No modification are allowed and must be the originally fitted and homologated part with no modifications allowed. The stator must be fitted in its original position and without offsetting.
- 9.3.2. The electric starter must operate normally and always be able to start the engine during the event.
- 9.3.3. During parc fermé the starter must crank the engine at a suit able speed for starting for a minimum of 2 seconds without the use of a boost battery.

Technical Regulations**10. Main frame**

- 10.1.** During the entire duration of the event, each rider can only use one (1) complete motorcycle, as presented for Technical Control, with the frame clearly identified with a seal. In case the frame will need to be replaced the rider or the team must request the use of a spare frame to the FMSCT/TSB Technical Director.
- 10.1.1. The pre-assembled spare part frame must be presented to the FMSCT/TSB Technical Director for the permission of rebuilding. The pre-assembly shall be strictly limited to:
- 10.1.1.1. Main frame
 - 10.1.1.2. Bearings (steering pipe, swing arm, etc)
 - 10.1.1.3. Swing arm
 - 10.1.1.4. Rear suspension linkage and shock absorber
 - 10.1.1.5. Upper and lower clamps (triple clamp, fork bridges)
 - 10.1.1.6. Wiring harness
- 10.1.2. The spare frame will not be allowed in the pit box before the rider or the team has received authorisation from the FMSCT/TSB Technical Director.
- 10.1.3. The rebuilt motorcycle must be inspected before its use by the technical stewards for safety checks and a new seal will be placed on the motorcycle frame.
- 10.1.4. Once the starting procedure is initiated, it isn't possible to verify a second motorcycle, neither in case of detention by red flag. In case of events with two races, once the first race is finished, the FMSCT/TSB Technical Director may allow the request for verification of a second motorcycle.

10.2. Frame body and Rear sub frame

- 10.2.1. The frame must remain as originally produced by the manufacturer for the homologated motorcycle.
- 10.2.2. Holes may be drilled on the frame only to fix approved components (i.e. fairing brackets, steering damper mount, sensors).
- 10.2.3. The sides of the frame-body may be covered by a protective part made of a composite material. These protectors must fit the form of the frame, but they must leave an empty place to add the technical control sticker close to the right side of the pivot frame.
- 10.2.4. Nothing else may be added or removed from the frame body.
- 10.2.5. All motorcycles must display a vehicle identification number punched on the frame body (chassis number).

Technical Regulations

- 10.2.6. Engine mounting brackets or plates must remain as originally produced by the manufacturer for the homologated motorcycle.
- 10.2.7. Front subframe/fairing mount may be changed or altered. but the use of titanium and carbon (or similar composite materials) is not allowed
- 10.2.8. Rear sub frame may be changed or altered, but the type of material must remain as homologated, or material of a higher specific weight.
- 10.2.9. Additional seat brackets may be added, non-stressed protruding brackets may be removed if they do not affect the safety of the construction or assembly. Bolt-on accessories to the rear sub-frame may be removed.
- 10.2.10. The paint scheme is not restricted but polishing the frame body or subframe is not allowed.

10.3. Front Forks

- 10.3.1. Front fork in whole or part may be changed but must be the same type homologated (leading link, telescopic, etc.). NB - Upside down is a type of telescopic. The aftermarket front fork must be homologated with FMSCT/TSB.
- 10.3.2. No aftermarket or prototype electronically-controlled suspensions can be used. If original electronic suspensions are used, they must be completely standard(any mechanical or electronic part must remain as homologated). The original electronic system must work properly in the event of an electric/electronic failure otherwise it cannot be homologated for FMSCT/TSB competitions.
- 10.3.3. The upper and lower fork clamps (triple clamp, fork bridges) can be changed or modified.
- 10.3.4. Steering damper may be added or replaced with an after market damper.
- 10.3.5. The steering damper cannot act as a steering lock limiting device.
- 10.3.6. Electronic controlled steering damper cannot be used if not installed in the homologated model for road use. However, it must be completely standard (any mechanical or electronic part must remain as homologated).

10.4. Rear fork (Swing arm)

- 10.4.1. The rear fork must remain as originally produced by the manufacturer for the homologated motorcycle.
- 10.4.2. Rear fork pivot bolt must remain as originally produced by the manufacturer for the homologated motorcycle.
- 10.4.3. Rear swingarm pivot position must remain in the homologated position (as supplied on the production bike). If the standard bike has inserts then the orientation/position of the original insert may be changed but the insert cannot be replaced or modified.

Technical Regulations

- 10.4.4. A solid protective cover (shark fin) shall be fixed to the swing-arm, and must always cover the opening between the lower chain run, swingarm and the rear wheel sprocket, irrespective of the position of the rear wheel to prevent any rider's body part that may become trapped between the lower chain run and rear wheel sprocket.
- 10.4.5. Rear wheel stand brackets may be added to the rear fork by welding or by bolts. Brackets must have rounded edges (with a large radius). Fastening screws must be recessed. An anchorage system or point(s) to keep the original rear brake calliper in place may be added to the rear swing-arm.
- 10.4.6. **Additional swingarm weights intended to influence suspension dynamics are prohibited, unless originally fitted on the homologated production motorcycle.**

10.5. Rear suspension unit

- 10.5.1. Rear suspension unit can be changed but a similar system must be used (i.e. dual or mono). The aftermarket rear suspension unit must be homologated with FMSCT/TSB.
- 10.5.2. No aftermarket or prototype electronic ally-controlled suspensions can be used. If original electronic suspensions are used, they must be completely standard (any mechanical or electronic part must remain as homologated). The original electronic system must work properly in the event of an electric/electronic failure otherwise it cannot be homologated for FMSCT/TSB competitions
- 10.5.3. The rear suspension linkage may be modified or replaced.
- 10.5.4. The original fixing points in the frame (if any) must be used to mount the shock absorber, linkage and rod assembly fulcrum (pivot points).

10.6. Wheels

- 10.6.1. Wheels may be replaced, and associated parts may be altered or replaced from those fitted to the homologated motorcycle.
- 10.6.2. Only wheels made from aluminium alloys are allowed.
- 10.6.3. The No Carbon (or similar composite materials) Wheels are permitted for all situations. If a Motorcycle is originally equipped with carbon wheels as standard than it MUST be changed to non-carbon wheels.
- 10.6.4. The wheels may be overpainted but the original finish cannot be removed.
- 10.6.5. Each specific racing wheel model must be approved and certified according to JASO (Japanese Automotive Standards Organization) T 203-85 where W (maximum design load) of art. 11.1.3 is 195 kg for front wheel and 195 kg for rear wheel, K = 1.5 for front and rear wheels. Static radius of tyre: front 0.301 m, rear 0.331 m.

Technical Regulations

10.6.6. Wheel balance weights may be discarded, changed or added to.

10.6.6.1. Any inner tube (if fitted) or inflation valves may be used.

10.6.6.2. Wheels must be made from aluminium alloys.

10.6.6.3. Wheel rim diameter size (front and rear) 17 inches

10.6.6.4. Front wheel rim width: 3.50 inches

10.6.6.5. Rear wheel rim width: 6.00 inches

10.7. Brakes

10.7.1. Front master cylinder may be altered or replaced from those fitted to the homologated motorcycle.

10.7.2. Rear master cylinder may be altered or replaced from those fitted to the homologated motorcycle.

10.7.3. Front calipers may be altered or replaced from those fitted to the homologated motorcycle.

10.7.4. Rear calipers may be altered or replaced from those fitted to the homologated motorcycle.

10.7.5. Brake pads or shoes may be altered or replaced from those fitted to the homologated motorcycle.

10.7.6. Brake hoses and brake couplings may be altered or replaced from those fitted to the homologated motorcycle.

10.7.7. The split of the front brake lines for both front brake calipers must be made above the lower fork bridge (lower triple clamp).

10.7.8. Brake discs may be altered or replaced from those fitted to the homologated motorcycle. Only ferrous materials are allowed for brake discs. The use of exotic alloy materials for discs and brake calipers (i.e. aluminum beryllium, etc.) is not allowed.

10.7.9. Anti Lock Braking Systems (ABS) are not permitted. An ABS replacement/bypass may be fitted and or the ABS unit may be dismantled to leave just its ECU.

10.7.10. Ducting and shielding on front brake is permitted.

10.7.11. Motorcycles must be equipped with brake lever protection, intended to protect the handlebar brake lever from being accidentally activated in case of collision with another motorcycle.

10.7.12. Thumb-operated rear brake systems are permitted. The use of a thumb or hand-operated rear brake is allowed in addition to, or as a replacement for, the standard foot-operated rear brake system.

Technical Regulations

10.7.12.1. An adaptor may be fitted to the reservoir inlet of the original rear master cylinder to enable connection of the thumb brake system

10.7.12.2. All components must be securely mounted and comply with safety standards. No modification to the rear brake caliper is permitted unless otherwise stated in these regulations.

10.8. Handle Bars and Hand Controls

- 10.8.1. Handle bars may be replaced.
- 10.8.2. Handle bars and hand controls may be relocated.
- 10.8.3. Throttle controls must be self closing when not held by the hand.
- 10.8.4. Throttle assembly and associated cables may be modified or replaced but the connection to the throttle body and to the throttle controls must remain as on the homologated motorcycle. Cable operated throttles (grip assembly) must be equipped with both an opening and a closing cable including when actuating a remote drive by wire grip/demand sensor.
- 10.8.5. Clutch and brake lever may be replaced with an after-market model. An adjuster to the brake lever is allowed.
- 10.8.6. Switches may be changed but the electric starter switch and engine stop switch must be located on the handlebars.
- 10.8.7. Motorcycles must be equipped with a functional ignition kill switch or button mounted on the right-hand handlebar (within reach of the hand while on the hand grips) that is capable of stopping a running engine. The button or switch must be red.
- 10.8.8. Motorcycles must be equipped with clutch and brake lever protection intended to protect the handlebar clutch and brake lever from being accidentally activated in case of collision with another Motorcycle.

10.9. Foot rest / Foot controls

- 10.9.1. Foot rest/foot controls may be relocated but brackets must be mounted to the frame in the original mounting points.
- 10.9.2. Foot rests may be rigidly mounted or a folding type which must incorporate a device to return them to the normal position.
- 10.9.3. The end of the foot rest must have at least an 8 mm solid spherical radius.
- 10.9.4. Non folding footrests must have an end (plug) which is permanently fixed, made of aluminium, plastic, Teflon® or an equivalent type material (minimum radius 8mm). The plug surface must be designed to reach the widest possible area. The FMSCT/TSB Technical Director has the right to refuse any plug not satisfying this safety aim.

10.10. Fuel tank

Technical Regulations

- 10.10.1. Fuel tank must remain as originally produced by the manufacturer for the homologated motorcycle.
- 10.10.2. All fuel tanks must be completely filled with fire retardant material (open-celled mesh, i.e. Explosafe).
- 10.10.3. Fuel tanks with tank breather pipes must be fitted with non-return valves that discharge into a catch tank with a minimum volume of 250cc made of a suitable material. or properly plugged with no loose end
- 10.10.4. Fuel cap must be changed for a “screw type” cap to prevent accidental opening at any time. Fuel cap when closed must be leak proof.
- 10.10.5. The sides of the fuel tank may be protected with a cover made of a composite material. These covers must fit the shape of the fuel tank.

10.11. Fairing / Body work

Fairings from different production years of the same motorcycle model may be used interchangeably, subject to the following conditions:

- 10.11.1. The fairing must be an original OEM component or an aftermarket replacement specifically manufactured for the same motorcycle model.
- 10.11.2. The fairing must retain the original external shape and aerodynamic profile of the homologated production model. Any modification to the aerodynamic design is strictly prohibited.
- 10.11.3. No aerodynamic devices or appendages may be added, including but not limited to wings, fins, air deflectors, or similar components intended to improve aerodynamic performance.
- 10.11.4. The original air ducts running between the fairing and the air box may be altered or replaced. Carbon fibre composites and other exotic materials are forbidden. Particle grills or “wire-meshes” originally installed in the openings for the air ducts may be taken away.
- 10.11.5. Windscreens must follow the original contour of the production fairing and must not exceed the standard dimensions or significantly alter the aerodynamic profile of the motorcycle. The edge of the screen must have no sharp edges
- 10.11.6. The original combination instrument/fairing brackets may be replaced, but the use of titanium and carbon (or similar composite materials) is forbidden. All other fairing brackets may be altered or replaced.
- 10.11.7. The lower fairing must to be constructed to hold, in case of an engine breakdown minimum 4 litres. The lower edge of all the openings in the fairing must be positioned at least 70 mm above the bottom of the fairing. The upper edge of the rear transverse wall of the lower fairing must be at least 70 mm above the bottom. The angle between this wall and the floor must be $\leq 90^\circ$.

Technical Regulations

- 10.11.8. The lower fairing must incorporate a single opening of Ø 25 mm diameter in the front lower area. This hole must remain sealed by rubber plug in dry conditions and must be only opened in wet race conditions. (To seal by adhesive tape is not allowed.)
- 10.11.9. Front mudguards may be replaced with a cosmetic duplicate of the original parts and may be spaced upward for increased tyre clearance.
- 10.11.10. Rear mudguard fixed on the swing arm may be modified, changed or removed
- 10.11.11. Motorcycles may be equipped with inner ducts to improve the air stream towards the radiator but the appearance of the front, the rear and the profile of the motorcycle must not be changed.
- 10.11.12. Fairings must not provide any performance advantage compared to the standard configuration of the homologated motorcycle model.
- 10.11.13. All fairings must allow clear and unobstructed display of competition numbers and mandatory sponsor decals as required by the sporting regulations.
- 10.11.14. The BRIC Technical Director reserves the right to inspect, measure, and reject any fairing deemed to provide an aerodynamic, structural, or performance advantage.

10.12. Seat

- 10.12.1. Seat, seat base and associated bodywork may be replaced with parts of similar appearance as originally produced by the manufacturer for the homologated motorcycle. The appearance from front, rear and profile must conform to the homologated shape
- 10.12.2. The top portion of the rear body work around the seat may be modified to a solo seat.
- 10.12.3. The homologated seat locking system (with plates, pins, rubber pads etc.) may be removed.

10.13. Rear Safety Light

- 10.13.1. All motorcycles must have a functioning red light mounted at the rear of the machine, to be used in rain or low visibility conditions. All lights must comply with the following:
 - 10.13.1.1. Lighting direction must be parallel to the machine centre line (motorcycle running direction), and be clearly visible from the rear at least 15 degrees to both left and right sides of the machine centre line.
 - 10.13.1.2. The rear light must be mounted near the end of the seat/rear bodywork and approximately on the machine centre line, in a position approved by the FMSCT/TSB Technical Director. In case of dispute over the

Technical Regulations

mounting position or visibility, the decision of the FMSCT/TSB Technical Director will be final.

- 10.13.1.3. Power output/luminosity equivalent to approximately: 10 – 15 (incandescent), 0.6 – 5 W (LED).
- 10.13.1.4. The output must be continuous - no flashing safety light whilst on track, flashing is allowed in the pit lane when pit limiter is active.
- 10.13.1.5. Safety light power supply may be separated from the motorcycle. Light shall be remain ON even in case of accident or crashed
- 10.13.1.6. Safety light must be able to turn ON/OFF from handlebar
- 10.13.1.7. The FMSCT/TSB Technical Director has the right to refuse any light system not satisfying this safety purpose.

10.14. Fasteners

- 10.14.1. Standard fasteners may be replaced with fasteners of any material and design but titanium fasteners cannot be used. The strength and design must be equal to or exceed the strength of the standard fastener.
- 10.14.2. Fasteners may be drilled for safety wire, but intentional weight-reduction modifications are not allowed.
- 10.14.3. Thread repair using inserts of different material such as helicoils and timeserts is allowed.
- 10.14.4. Fairing / bodywork fasteners may be replaced with the quick disconnect type.
- 10.14.5. Aluminium fasteners may only be used in non-structural locations.

11. The following items **MAY** be altered or replaced from those fitted to the homologated motorcycle.

- 11.1. Any type of lubrication, brake or suspension fluid may be used.
- 11.2. Gaskets and gasket materials.
- 11.3. Instruments, instrument bracket(s) and associated cables.
- 11.4. Painted external surface finishes and decals.
- 11.5. Material for brackets connecting non original parts (fairing, exhaust, instruments, etc) to the frame (or engine) cannot be made from titanium or fibre reinforced composites.
- 11.6. Protective covers for the frame, chain, footrests, etc. may be made in other materials like fibre composite material if these parts do not replace original parts mounted on the homologated model.

12. The Following Items **MAY BE** Removed

Technical Regulations

- 12.1. Emission control items (anti-pollution) in or around the air box and engine (O2 sensors, air injection devices).
- 12.2. Tachometer.
- 12.3. Speedometer.
- 12.4. Chain guard as long as it is not incorporated in the rear fender.
- 12.5. Bolt-on accessories on a rear subframe.

13. The Following Items MUST BE Removed

- 13.1. Headlamp, rear lamp and turn signal indicators (when not incorporated in the fairing). Openings must be covered by suitable materials.
- 13.2. Rear-view mirrors.
- 13.3. Horn.
- 13.4. License plate bracket.
- 13.5. Toolkit.
- 13.6. Helmet hooks and luggage carrier hooks
- 13.7. Passenger foot rests.
- 13.8. Passenger grab rails.
- 13.9. Safety bars, centre and side stands must be removed (fixed brackets must remain).

14. The Following Items MUST BE Altered

- 14.1. Motorcycles must be equipped with a functional ignition kill switch or button mounted on the right hand handlebar (within reach of the hand while on the hand grips) that is capable of stopping a running engine, the button or switch must be red
- 14.2. All motorcycles must have a closed breather system. The oil breather line must be connected and discharge in the airbox.
- 14.3. The following items must be securely safety wired
 - 14.3.1. Oil drain plug
 - 14.3.2. Oil filler cap and oil level measurement rod (Dip stick)
 - 14.3.3. External Oil filter
 - 14.3.4. All wheel axle nuts (or alternately being appropriately attached with safety pins or lock nut)

Technical Regulations

14.3.5. Front brake caliper

- 14.4.** Where breather or overflow pipes are fitted they must discharge via existing outlets. The original closed system must be retained: no direct atmospheric emission is permitted.
- 14.5.** Motorcycles must be equipped with a red light on the instrument panel that will illuminate in the event of oil pressure drop.

15. Homologated Parts

- 15.1.** Homologated parts are the OEM parts supplied fitted to the machine during manufacture and as delivered. Unless stated otherwise these parts may not be remade, refinished, treated.
- 15.2.** Coated or modified in any way. Parts from the different homologations may not be used on the machines from another homologation including when sharing the model name but excepting when the part is superseded for production reasons and also accepted by the FIM and FIM Asia.
- 15.3.** As originally fitted or equipped on the homologated Motorcycle. Interchange of parts between the Motorcycles within same model name and or same frame VIN (Vehicle Identification Numbers) where they are homologated separately and at different years are NOT PERMITTED, except when it is specifically mentioned in another part(s) of this regulation that it can be interchanged between the Motorcycles within same model name and or same frame VIN. (E.g. Wheels)
- 15.4.** Controlled homologated parts are meant for controlling mechanical parts which effecting vehicle performance not concerning exterior or cosmetic parts. Such parts as fairing shall be follow according to specific clauses.

Appendix 1: Engine seal

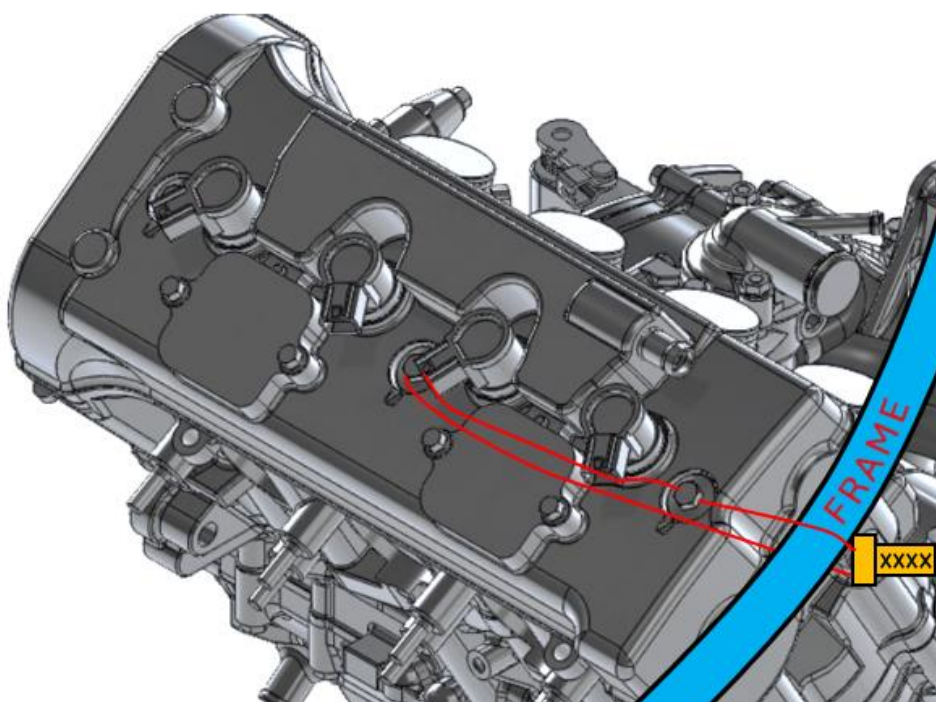

Technical Regulations

Updated by Jitphum Sirivechapun, 20 march 2026

FMSCT/ TSB Chief Technical Scrutineer, FMSCT All Thailand Super Bikes Race Direction